

StoGuard® Waterproof Air Barrier Frame Construction

Brick Ledge at Foundation Wood Frame

Date: April 2012

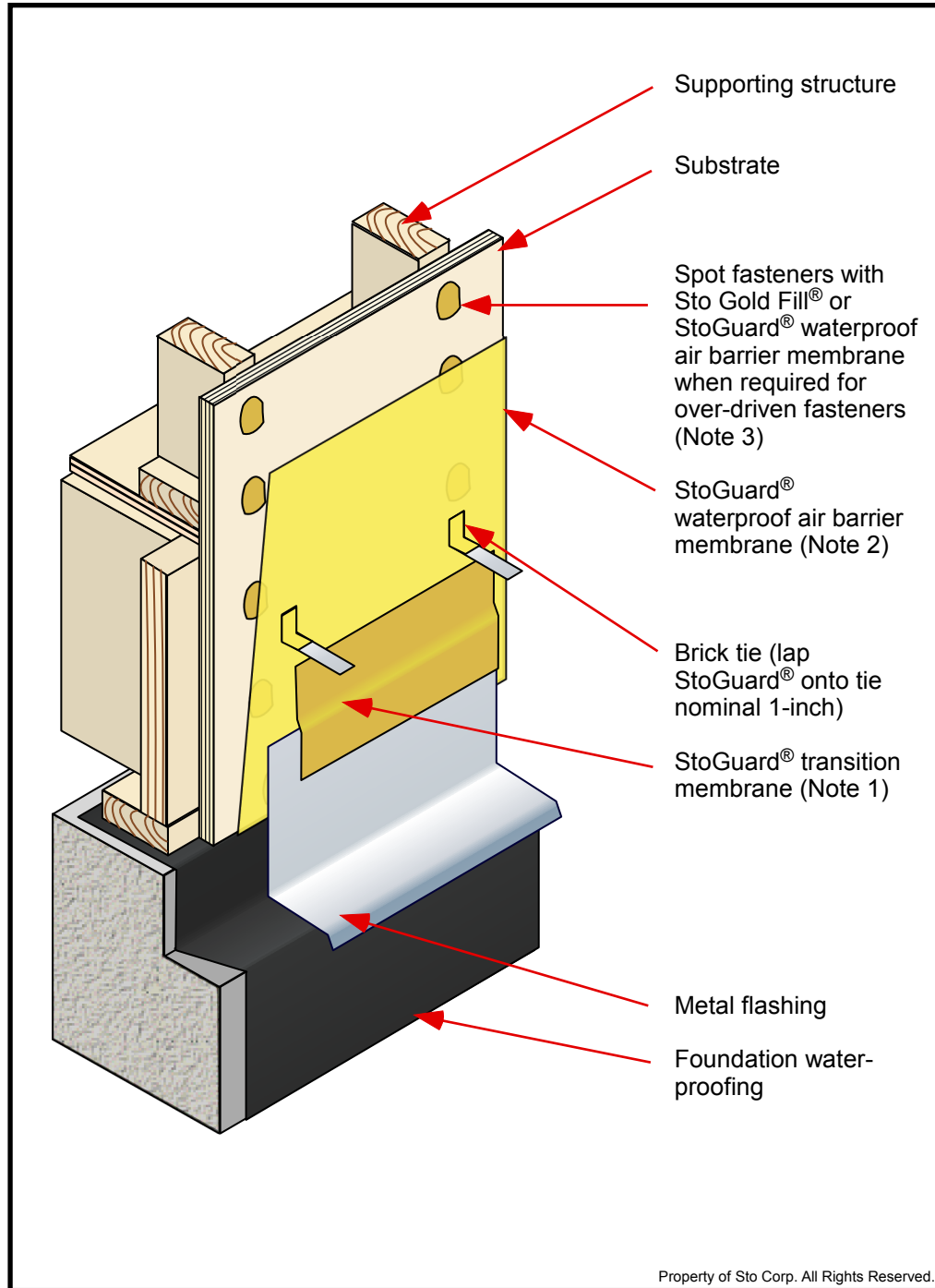

Notes:

- 1) StoGuard® transition membrane options:
 - A) StoGuard® RapidSeal™
 - B) Sto Gold Fill® with StoGuard® Mesh (top coated with StoGuard waterproof air barrier membrane)
 - C) StoGuard® Fabric with StoGuard® waterproof air barrier membrane
 - D) StoGuard® Tape (with StoGuard® Fabric shingle lap)
- 2) StoGuard® waterproof air barrier membrane options:
 - A) Sto Gold Coat® (vapor permeable)
 - B) Sto EmeraldCoat® (high perm)
 - C) StoGuard® VaporSeal™ (vapor impermeable)
 - D) Sto AirSeal™ (high perm)
- 3) Refer to Sto specifications and product bulletins for detailed information on substrates and Sto material options.

IMPORTANT: Components not identified as Sto are furnished by other manufacturers and are not necessarily installed by trades who install the Sto products. Refer to project specific contract documents.

Property of Sto Corp. All Rights Reserved.

Attention

Sto products are intended for use by qualified professional contractors, not consumers, as a component of a larger construction assembly as specified by a qualified design professional, general contractor or builder. They should be installed in accordance with those specifications and Sto's instructions. Sto Corp. disclaims all, and assumes no, liability for on-site inspections, for its products applied improperly, or by unqualified persons or entities, or as part of an improperly designed or constructed building, for the nonperformance of adjacent building components or assemblies, or for other construction activities beyond Sto's control. Improper use of Sto products or use as part of an improperly designed or constructed larger assembly or building may result in serious damage to Sto products, and to the structure of the building or its components. **STO CORP. DISCLAIMS ALL WARRANTIES EXPRESS OR IMPLIED EXCEPT FOR EXPLICIT LIMITED WRITTEN WARRANTIES ISSUED TO AND ACCEPTED BY BUILDING OWNERS IN ACCORDANCE WITH STO'S WARRANTY PROGRAMS WHICH ARE SUBJECT TO CHANGE FROM TIME TO TIME.** For the fullest, most current information on proper application, clean-up, mixing and other specifications and warranties, cautions and disclaimers, please refer to the Sto Corp. website, www.stocorp.com.

www.stocorp.com